

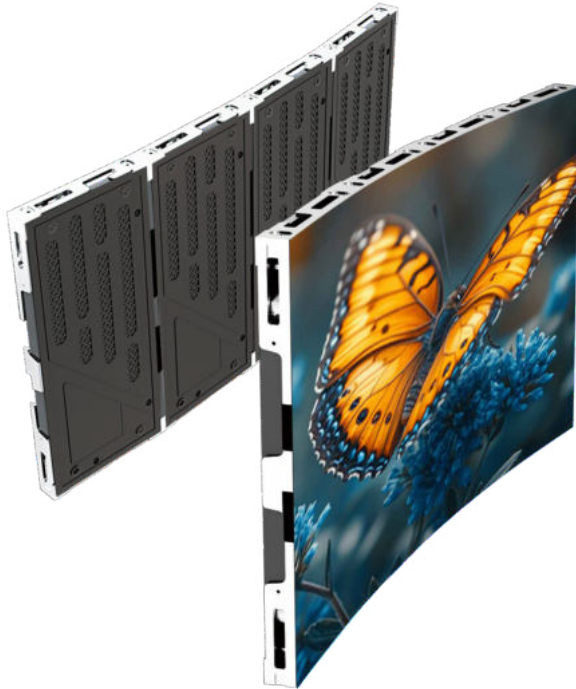

# SA-XCH SERIES

CURVE INDOOR LED VIDEO WALL



## FEATURE

- Available in P0.7, P0.9, P1.2, P1.5, P1.8, P2.5 pixel pitches
- Front Maintenance for convenient and efficient servicing.
- Back-Up functionality for enhanced reliability and backup support.
- High Refresh Rate for smooth motion and stable performance.
- Super Thin and Lightweight design for easy installation and flexible use.
- Wide Viewing Angle to ensure clear visibility from multiple positions.
- Creative Styling options to support flexible design and visual appeal.
- High Gray Scale for richer colors and more natural image gradients.

- **Multifunctional design** to meet a wide range of display needs.
- **Compact 150mm cabinet** that can be customized to your specifications.
- **Flexible 150mm cabinet system:** up to 4 x 150mm cabinets can be combined to form a 600mm cabinet, enabling scalable screen configurations.

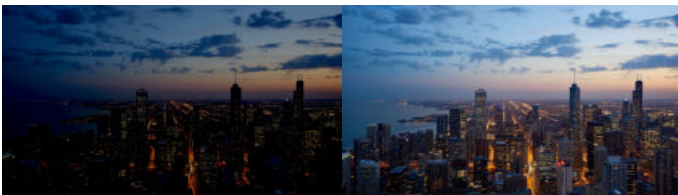

High brightness, high grayscale, high refresh rate, no scanning line for taking photos

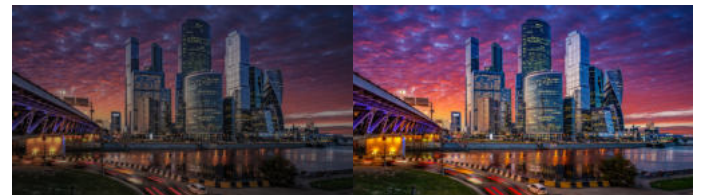

Professional color management techniques, rich color layers and more natural color transitions

DESIGNED TO BE COMPATIBLE WITH CHRISTIE'S IMAGE CONTROL SYSTEM

Starview SA-XCH-Series

Supported control solution	Switchers and AV distribution	<ul style="list-style-type: none"> <li>• Terra Controller</li> <li>• Terra Receiver</li> <li>• Terra Transmitter</li> </ul>
	Video wall processors	<ul style="list-style-type: none"> <li>• Hedra Standard</li> <li>• Hedra Pro-KVM</li> <li>• Hedra Pro-Video</li> </ul>
	Image processors	<ul style="list-style-type: none"> <li>• Spyder-S-Series</li> <li>• Mastering Gateway</li> <li>• Spyder X80</li> </ul>

Products "SA-XCH Series" manufactured by Starview, are paired with Christie Terra Switchers and AV distribution

Solutions beyond matrix switching for AV-over-IP system architectures

Based on off-the-shelf 10G Ethernet components, the Terra solution allows for the design of simple, flexible and highly-scalable system architectures that deliver great performance and user experience at a drastically lower total cost of ownership.

- **Terra Transmitter** - Supply audiovisual sources and control signals with uncompressed, zero-frame latency, artifact-free content over 10G networks.
- **Terra Receiver** - Deliver audiovisual sources and control from an SDVoE system to displays and other devices. Benefit from full signal management including videowall magnification, KVM switching and extension, aspect ratio management, and Multiviewer for confidence monitoring.
- **Terra Controller** - The Christie Terra Controller gives you complete, secure operational control and management over Terra devices and SDVoE systems.



Christie Hedra

Paired with Christie Hedra Video wall processors

Whether it's mission-critical operations or monitoring sources for energy and utilities, your team needs to securely display, arrange, and operate multiple sources to make quick, informed decisions. And that's where the new Christie® video wall processors come in.

With Christie Hedra™, you get secure, real-time access to your data that you can control from virtually anywhere for seamless collaboration and sharing of critical information so you can make those decisions.

Paired with Christie Spyder Image processors

Deliver the highest quality content every time

No matter what your canvas is - a live event, sports venue, control room, or corporate space - Christie® image processors and compositors can deliver the highest quality content with the lowest latency.

Christie Spyder-S Series: A revolution in compositing and processing

The Spyder-S Series redefines everything you know about compositing and processing with a better solution for live events, sports venues, and broadcast. Featuring a modular, scalable technology that lets you scale your system by combining individual nodes for nearly limitless inputs, outputs, and megapixels with ultra-low latency. It's everything you need and nothing you don't.

Christie Spyder X80: Designed for demanding events

An undisputed leader in its class, Spyder X80 is a powerful multi-screen windowing processor that offers performance, control, and flexibility for the most demanding, spectacular experiences imaginable.



Christie Spyder

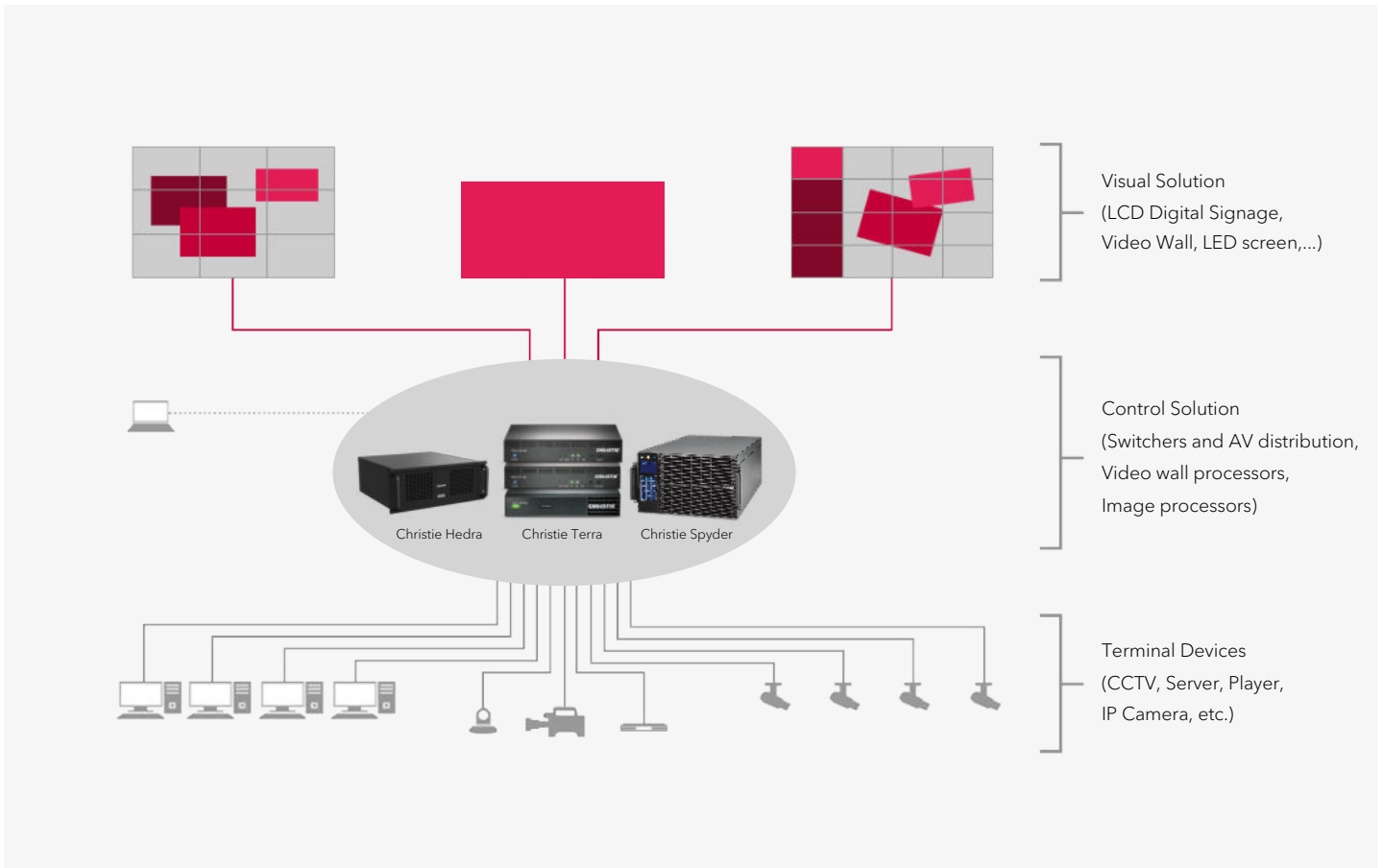

For technical or sales support, please visit:  
[www.starviewint.asia](http://www.starviewint.asia)

For assistance with confirming the Jurisdiction & Classification of Starview Asia products, please contact [info@starviewint.asia](mailto:info@starviewint.asia)

Copyright © 2025 STARVIEW ASIA. All rights reserved.  
 Australia Headquarters: Level 40, 140 Williams Street, Melbourne VIC 3000, Australia

## PRODUCT ADVANTAGES

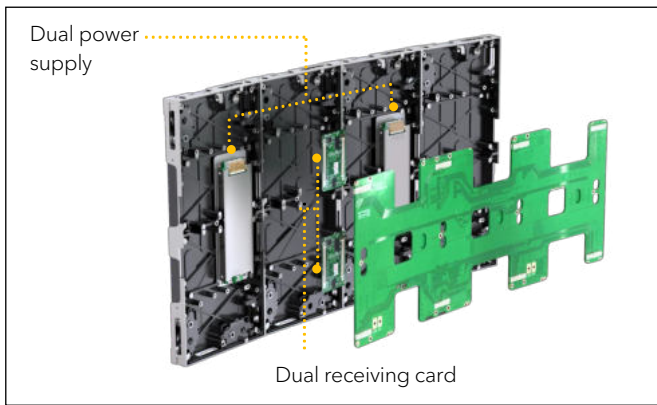

### Dual card dual electric (Optional)

Power supply not interrupted, signal not lost, more stable and reliable



### Curve-shape

Supporting inner and outer arc splicing, creating various curved shapes

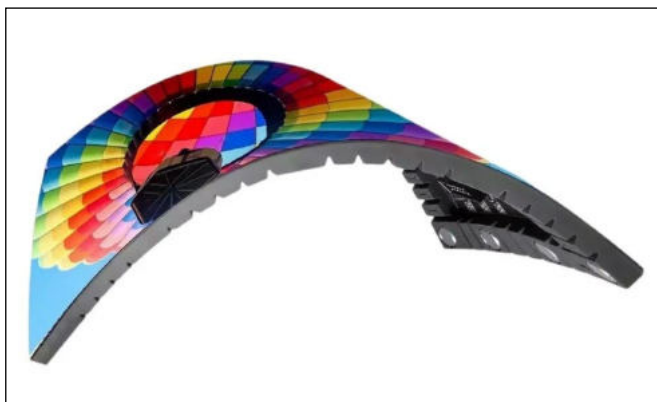

### Good flexibility

Module with small-unit and flexible design, makes possibility of more complicated shapes for the video show.

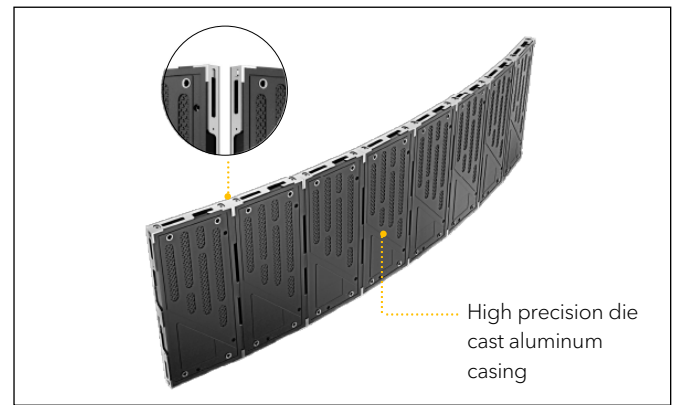

### Seamless splicing

Adopting CNC high-precision die cast aluminum casing, hard link design, anti collision concave and convex platform, multi-dimensional improvement of screen flatness

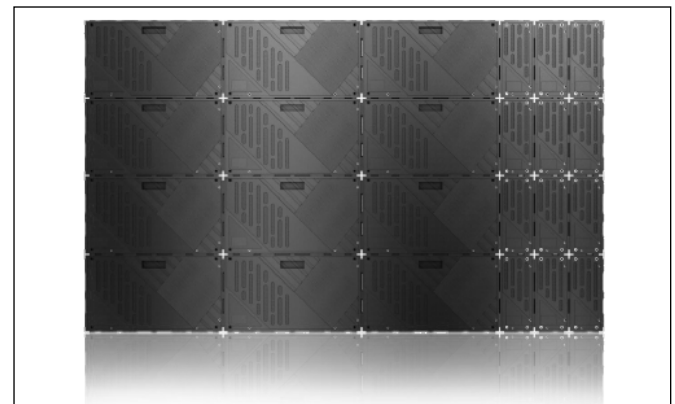

### Flat screen

150mm small cabinet flexibly supplement the size, improve the required size matching

For technical or sales support, please visit:  
[www.starviewint.asia](http://www.starviewint.asia)

For assistance with confirming the Jurisdiction & Classification of Starview Asia products, please contact [info@starviewint.asia](mailto:info@starviewint.asia)

Copyright © 2025 STARVIEW ASIA. All rights reserved.  
Australia Headquarters: Level 40, 140 Williams Street, Melbourne VIC 3000, Australia

## Technical specifications

## SA-XCH SERIES

Model	SA-XCH-P0.7	SA-XCH-P0.9	SA-XCH-P1.2	SA-XCH-P1.5	SA-XCH-P1.8	SA-XCH-P2.5
Pixel Pitch (mm)	0.78	0.9375	1.25	1.56	1.875	2.5
LED Type	Mini 4 in 1	COB	SMD1010, RGB 3-in-1	SMD1212, RGB 3-in-1	SMD1515, RGB 3-in-1	SMD1515/GOB, RGB 3-in-1
Physical Density (pixel/m <sup>2</sup> )	1,638,400	1,137,778	640,000	409,600	284,444	160,000
Module Resolution (W x H) (pixel)	192x216	160x180	120x270	96x216	80x180	60x135
Module Size (W x H) (mm) (Customize)	150x168.75	150x168.75	150x337.5	150x337.5	150x337.5	150x337.5
Cabinet Resolution (W x H)	768x432	640x360	480x270	384x216	320x180	240x135
Cabinet Size (W x H x D) (mm)	600x337.5x27.5 (Customize)					
Module Quantity (W x H)	4x2	4x2	4x1	4x1	4x1	4x1
Cabinet Weight (kg)	4.5					
Cabinet Material	Die-casting Aluminium					
Brightness Calibration	Have					
Brightness of White Balance (nits)	800-1200					
Brightness Control	>1200 nits					
Brighness Level	Auto/Manual: 256 Levels					
Support HDR, HLG	Yes					
Color Temperature (°K)	3,200 - 9,000°K Adjustable					
Viewing Angle (V/H)	160°/160°					
Brightness Uniformity	≥99.8%					
Contrast Ratio	15,000 : 1					
Driver IC	ICN1065L					
Frame Rate (Hz)	50/60					
Drive Mode	1/64 scan	1/60scan	1/45 scan	1/48 scan	1/45 scan	1/30 scan
Display Color	14 bit					
Refresh Rate (Hz)	3,840					
Heat Output Per Sqm	338 BTU/hr typical, 1050 BTU/hr maximum					
Power Supply	100-240 VAC @50/60Hz (Use power adapter: Meanwell UHP-200A-5)					
Max. Power Consumption (W/m <sup>2</sup> )	350					
Avg. Power Consumption (W/m <sup>2</sup> )	100					
Protection	IP31					
Salt Tolerance (optional)	NEMA 4X					
Runtime	24/7					
Lifetime (hours)	100,000					
Installation and Service Access	Front Access, module removal. All internal electronics accessible					
Installation Options	Standard Flat Wall   U/L shape   Curved   Ceiling					
Install Orientation	Landscape/ Portrait					
Communication	LAN: 120m (no repeating); Optical Fiber Transmission: 500m - 10km					
System Platform	Compatible with Starview CMS DSS-SW platform					
Receiving Card	MRV532					
Working Temperature/Humidity (°C/RH)	-20~60°C/10%~85% (non-condensing)					
Storage Temperature/Humidity (°C/RH)	-20~60°C/10%~85% (non-condensing)					
Certification* (Optional)	CCC/ CE/ RoHS/ FCC/ EMC/ Safety 60950-1/ EN 13501-1					

\*The listed certifications are issued for markets in different regions. For the current status of the listed certifications in your region, please contact an authorized Starview representative.

## DIMENSION

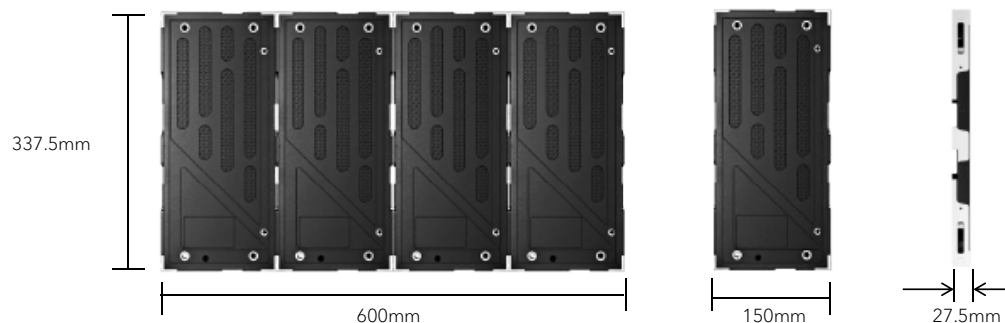

For technical or sales support, please visit:

[www.starviewint.asia](http://www.starviewint.asia)

Performance specifications are typical. Due to constant research, specifications are subject to change without notice. For the most up-to-date specifications, please contact an authorized Starview representative.

For assistance with confirming the Jurisdiction & Classification of Starview Asia products, please contact [info@starviewint.asia](mailto:info@starviewint.asia)

Copyright © 2025 STARVIEW ASIA. All rights reserved.  
Australia Headquarters: Level 40, 140 Williams Street, Melbourne VIC 3000, Australia