



DESCRIPTION

The Starview MS-30P is a wall mount speaker built-in 70v/100v transformer. The 70v/100v transformer technique reduces line losses on longer distance and allows easy parallel connection of multiple loudspeakers. The built-in 5"+1.5" two ways speaker driver is designed of wide frequency response 125-14kHz, the multiple power taps 3.75W, 7.5W, 15W & 30W are helpful for different applications varies from room size and ambient noise surroundings. The metal grille, ABS enclosure and stainless mounting bracket are of black color. Easy and secure wall mount installation through the supplied mounting kit. It is ideal choice for industrial and commercial applications in hotel, school, office and factory where background music and paging is needed.

KEY FEATURES

- Built-in 100v/70v transformer
- Wall mount type loudspeaker
- 5" + 1.5" two ways speaker unit
- Power taps 3.75w-7.5w-15w-30w @100V plus 8ohm
- Metal grille, ABS enclosure and stainless mounting bracket

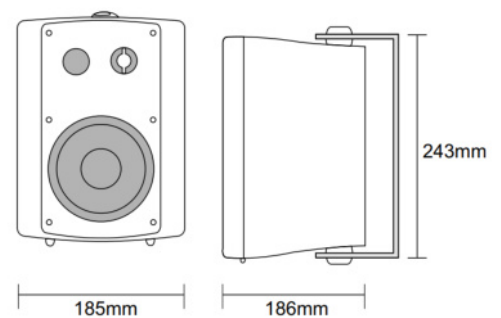

Website: www.starviewtech.asia or www.starviewtech.net | Email: sales@starviewint.com | Tell: +65 31575338

SPECIFICATION

STARVIEW MS-30P WALL MOUNT SPEAKER SPECIFICATIONS	
Power Taps @100V	3.75W, 7.5W, 15W, 30W
Power Taps @70V	1.9W, 3.75W, 7.5W, 15W, 30W
Transformer Impedance	2.6K Ω /1.3K Ω /670 Ω /330 Ω /165 Ω
Input	70V/100V/8 Ω
SPL(1W/1M)	92dB
Max. SPL (Rated W/1M)	107dB
Frequency Response (-10dB)	125 - 18KHz
Finish	Baffle: ABS, Black/White; Grille: Steel, Black/White
Speaker Driver	5" x 1; 1.5" x 1
Dimensions	243 x 185 x 186mm
Weight	2.7kg
Mounting	With mounting bracket fixed by screw

Direction Diagram

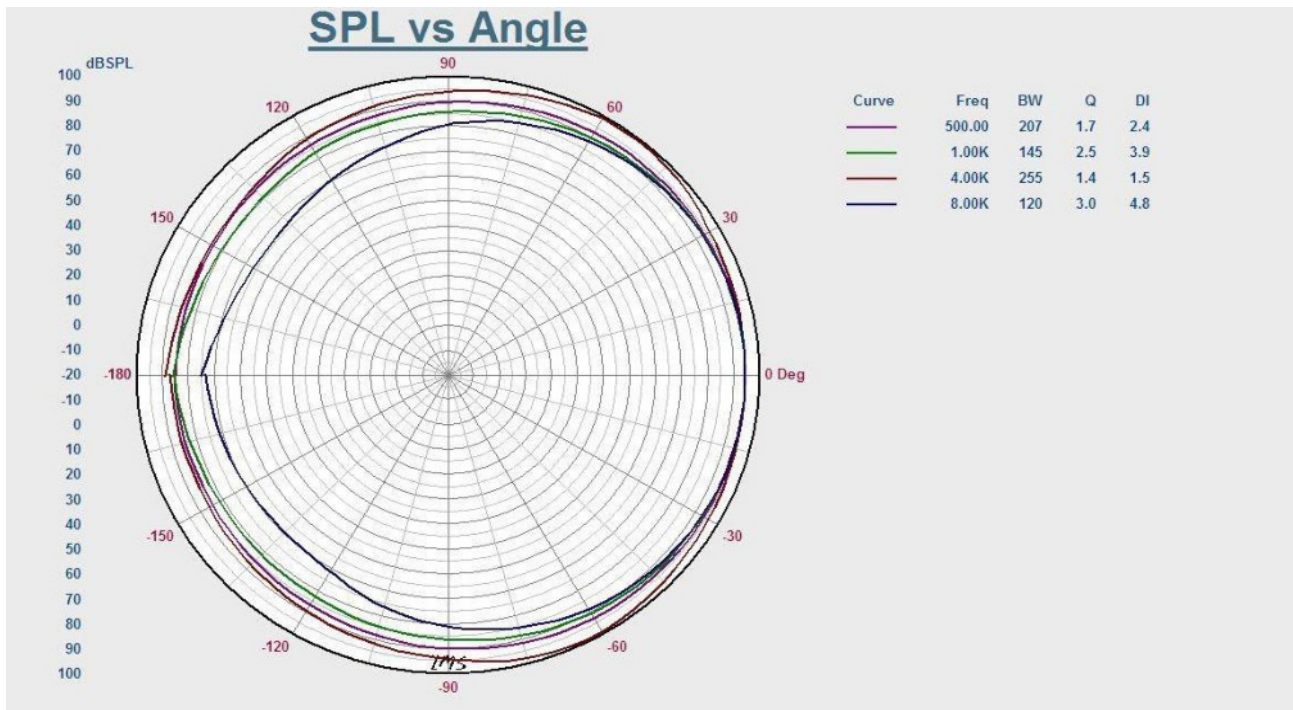

Website: www.starviewtech.asia or www.starviewtech.net | Email: sales@starviewint.com | Tel: +65 31575338

Frequency Response

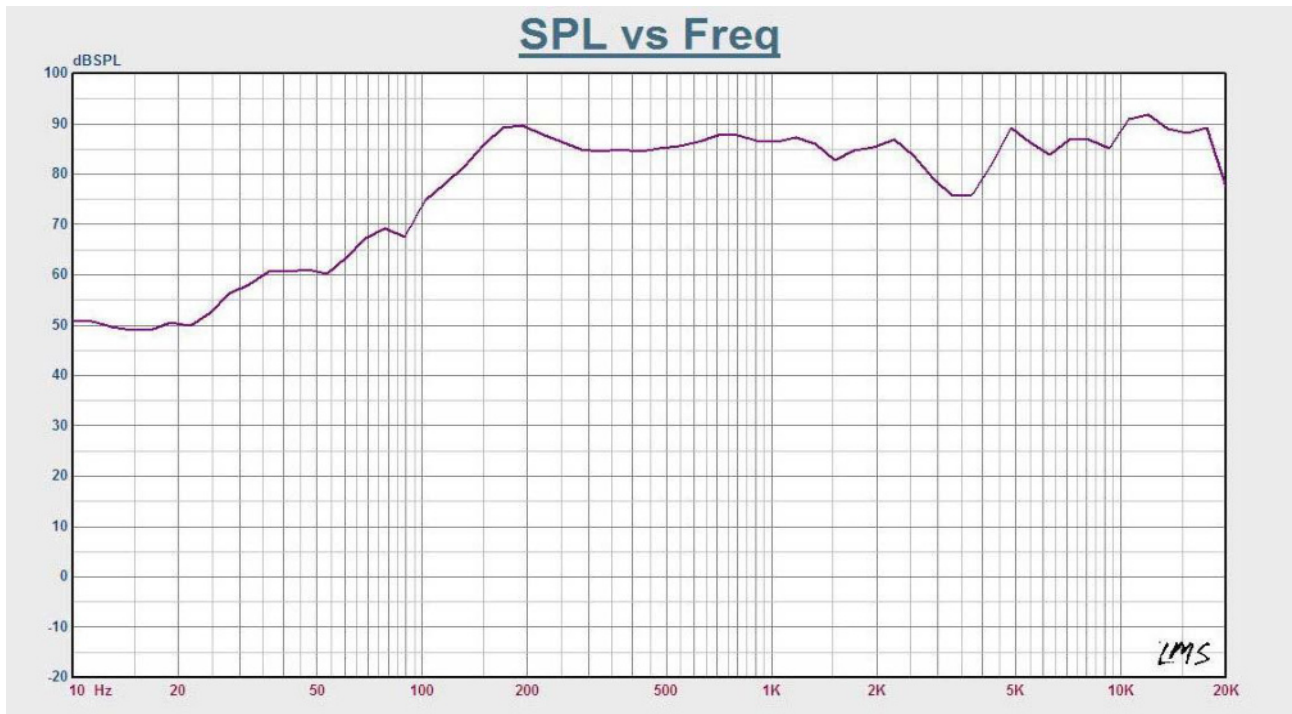

Corporate offices

STARVIEW TECHNOLOGIES PTE LTD
Singapore Headquarters
 60 Kaki Bukit Place
 #05-19 Eunos Techpark
 Singapore 415979

Tel: +65 3157 5338
 Fax: +65 3112 8181

Worldwide offices

Vietnam
Hanoi Office
 R9, 33th Floor, C2 Building, D'Capitale,
 119 Tran Duy Hung Street,
 Trung Hoa - Cau Giay, Hanoi
Ho Chi Minh Office
 #C9-16, Block A, Sky Center Building,
 #10 Pho Quang Street,
 Tan Binh District, Ho Chi Minh City
Danang Office
 Add: Suite 607, Floor 6th Altara Suites
 by Ri-yaz 120 Vo Nguyen Giap, Phuoc My,
 Son Tra, Danang

Tel: (024) 66661268
 Hotline: 19008695
 Sale Contact: 0866.207.855

Australia
NGITECH PTY LTD
 Level 40 140 Williams Street
 Melbourne VIC 3000
 Tel: +61 455 225 908

Representatives

Brazil
 Tel: +55 11 9-8244-7630

Germany
 Tel: +49 172 946 69 39

France - Benelux - Africa
 Tel: +33 782 702 214

Southern, Eastern Europe & Middle East Operations
 Tel: +420 602 66 75 66

